

Lubricate all seals with clean hydraulic fluid, prior to assembly. Do not use silicone type lubricants.

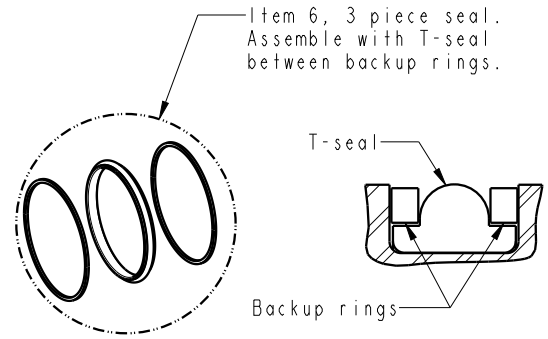
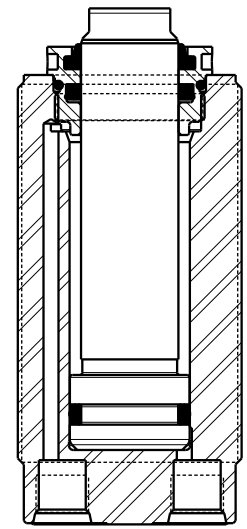
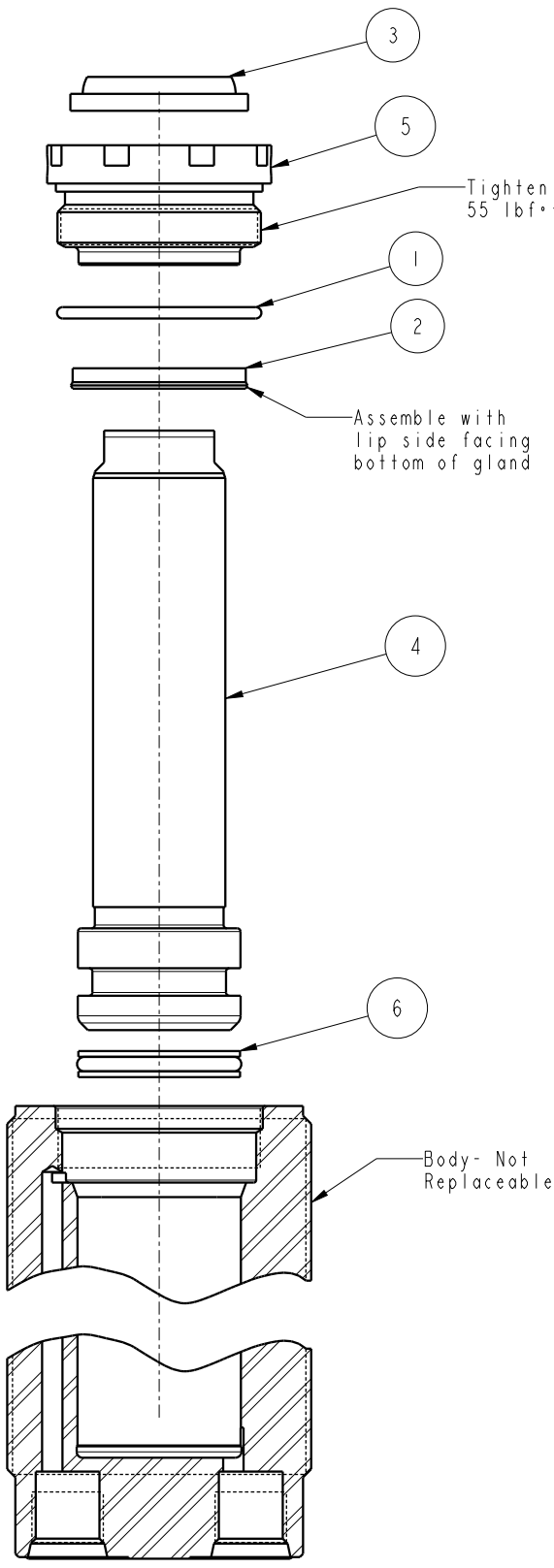

Standard Seal Kit	Fluorocarbon Seal Kit
60-2002-10	6V-2002-09
39-H100-17	39-V100-17
39-0110-45	39-0120-05
39-0010-11	39-0120-13
39-0120-08	39-0120-08

No.	QTY	PART No.	DESCRIPTION
6	1	39H10017	SEAL, T, (13/16 X 5/32 X 1)
5	1	82031002	GLAND, CYL, 3900 & 17.8 KN
4	1	82011006	PISTON, CYL, 3900, 2 STRK
3	1	39012008	WIPER, SNAP-IN, (13/16)
2	1	39011045	SEAL, LL, (13/16 X 1/8 X 1/8 X 1-1/16)
1	1	39001011	O-RING, (-024)

### PARTS LIST

**Model Number**  
20-0210-02  
20-0210-02F

VEKTEK, INC.  
1334 E. SIXTH AVE. P.O. BOX 625  
EMPORIA, KS. 66801 U.S.A.

ASSY, CYL, TB, 3900, 2 STRK, DA	
SIZE A	REV G

G	5499	RELEASE	NPETERS	9/23/24
REV	IN ACCORDANCE WITH ECN	EFFECTIVE DATE	REVISED BY	DATE
DRW BY: JACOB	<b>DRAWING STATUS: Released</b> PRODUCTION APPROVED FOR RELEASED STATUS ONLY			
DATE: 7/16/90				